

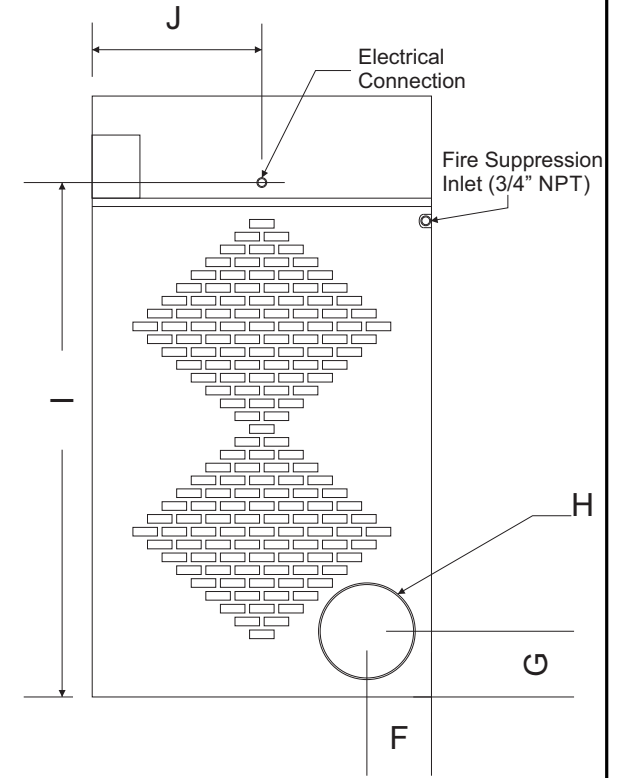

A

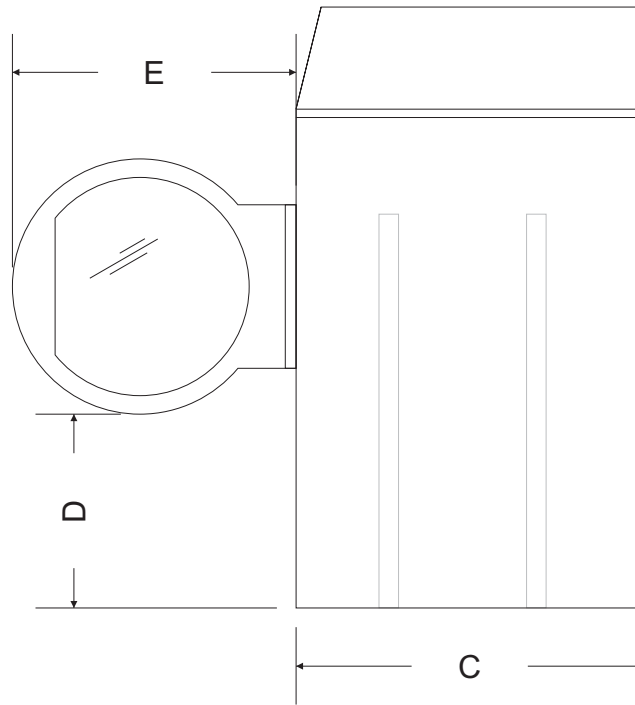
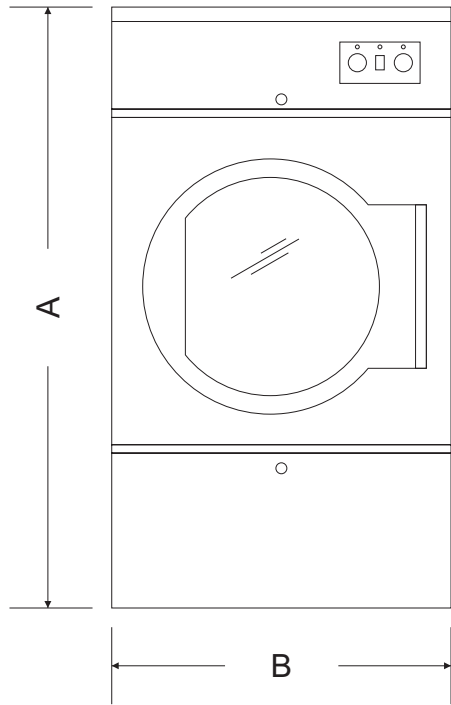

		DE-30					DE-30	
		English	Metric	Air Flow	CFM	cmm	500	14
A	Cabinet Height	73	1854	Heat Input	kW		24	
B	Cabinet Width	31.5	800	Electrical Requirements				
C	Cabinet Depth	42	1067	240V, 50/60Hz, 3PH	Amp	Breaker	66	80
D	Door Height	32.25	819	380-440V, 50/60Hz, 3PH	Amp	Breaker	33	40
E	Door Swing	27.75	705					
F	Exhaust Horizontal	6	152					
G	Exhaust Vertical	20	508					
H	Exhaust Diameter	8	203					
I	Height to Electrical Inlet	63.75	1619					
J	Side to Electrical Inlet	12.75	324					
	Shipping Weight	630	286					
	Net Weight	612	278					

REV	BY	DATE	REV. DESCRIPTION
A3	AFA	02/10/2023	Updated dimensions
DRAWN BY		DATE	 Panama City, FL Phone: 850-249-2222 Fax: 850-249-2226 www.bandctech.com
A. Adcock		9-30-2013	
CHECKED BY		DATE	
C. Oswald		9-30-2013	
DESCRIPTION			
General Technical Specifications DE-30 Electric Dryer			
DATE	FILE NAME	SHEET	
9-30-2013	DE-30 Electric Layout.cdr	1 OF 1	